

Artwork Guidelines

AWARD-WINNING REGISTRATION AND BADGING SOLUTIONS



YOUR EVENT. OUR SERVICE.

Full badging & registration solution

Printing and Design Specifications:

The standard plastic badge measures 85.5mm x 54mm. Please include a 3mm bleed in your design.

For images and text that are not intended to bleed, maintain a margin of at least 4mm from the card edge.

Keep in mind that the badge will have a 3mm radius corner, so be sure to account for this when positioning images and text.

Attachment and Layout Considerations:

If your badge or luggage tag requires a hole or slot, ensure that all images and text are at least 4mm clear of the edge of the hole or slot. A punched hole has a diameter of 5mm, with its top edge positioned 4mm from the card edge. A punched slot measures 14mm wide by 3mm high, with the top edge 4mm from the card edge.

Barcode Requirements:

If barcodes are to be included, they must be printed on a plain white area or on a very light colour tint that is at least 50mm wide by 20mm high. This area should be clear of the edges and slots.

Artwork Preparation:

Create artwork in CMYK colour mode at a resolution of 300 dpi.

Badges are printed single-sided (with the option of double-sided). If specific artwork is required for the back of the badge, please provide a separate file for each side.

File Formats and Submission:

The preferred file format for artwork submission is PDF.

We also accept AI, EPS, TIFF, or JPEG formats. If submitting JPEG files, ensure they are saved at maximum quality with minimal compression.

Important Notes:

Do not include trim marks, cut lines, badge outlines, hole/slot outlines, or any other printing guides in the artwork.

Please include a 3mm bleed on all sides.

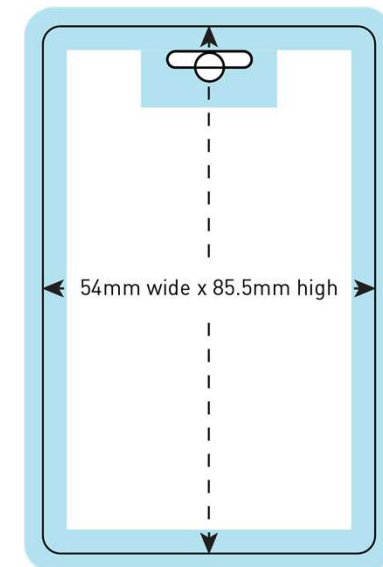
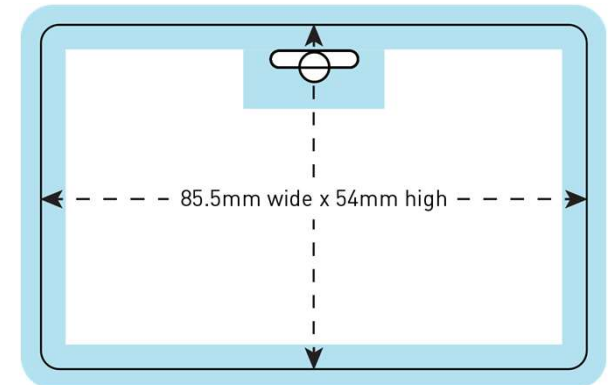

Image shown includes bleed