

Artwork Guidelines

AWARD-WINNING REGISTRATION AND BADGING SOLUTIONS



YOUR EVENT. OUR SERVICE.

Full badging & registration solution

Cardstock	3
Fanfold Large	4
Fanfold Standard	5
Butterfly Large	6
Butterfly Standard	7
Plastic	8
A6 Paper	9
PrintPod	10
ScanPod	11

Printing and Design Specifications:

Cardstock badges are printed in full colour in a single pass. Once printed, the badge folds in half and can be attached to a lanyard or clip.

The Cardstock dimensions are 98mm wide by 134mm high.

For images and text included in the artwork, please maintain a margin of at least 5mm from the edge of the badge.

Attachment and Layout Considerations:

The top of the badge includes three slots for lanyard attachment. Ensure your design accommodates these slots and avoids placing any logos, text, or important elements within the top 15mm of the badge.

Barcode Requirements:

If barcodes are to be included, they must be printed on a plain white area or on a very light colour tint that is at least 50mm wide by 20mm high. This area should be clear of the edges and slots.

Artwork Preparation:

Create artwork in CMYK colour mode at a resolution of 300 dpi.

Badges are printed with the same artwork for the front and the back (when folded). If different artwork is required for the back, please provide separate files for each side.

File Formats and Submission:

The preferred file format for artwork submission is PDF.

We also accept AI, EPS, TIFF, or JPEG formats. If submitting JPEG files, ensure they are saved at maximum quality with minimal compression.

Important Notes:

Do not include trim marks, cut lines, badge outlines, hole/slot outlines, or any other printing guides in the artwork.

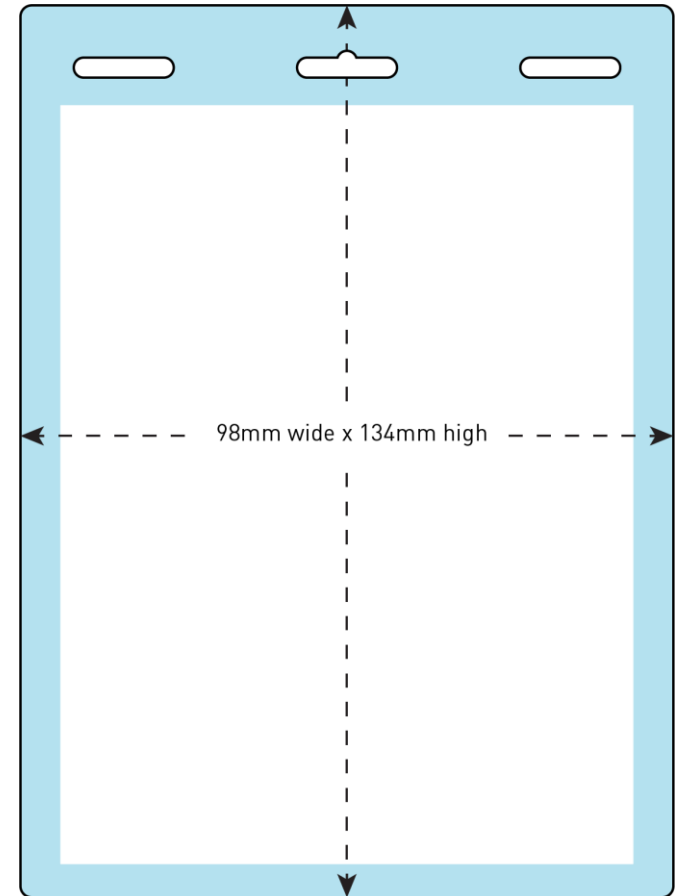

Printing and Design Specifications:

Fanfold badges are printed in one pass in full colour, on a carrier sheet. When printed the badge is peeled off, folded in half, and can then be attached to a lanyard or clip.

The Fanfold Large dimensions are 96mm wide by 134mm high.

For images and text included in the artwork, please maintain a margin of at least 5mm from the edge of the badge.

Attachment and Layout Considerations:

The top of the badge includes three slots for lanyard attachment. Ensure your design accommodates these slots and avoids placing any logos, text, or important elements within the top 15mm of the badge.

Barcode Requirements:

If barcodes are to be included, they must be printed on a plain white area or on a very light colour tint that is at least 50mm wide by 20mm high. This area should be clear of the edges and slots.

Artwork Preparation:

Create artwork in CMYK colour mode at a resolution of 300 dpi.

Badges are printed with the same artwork for the front and the back (when folded). If different artwork is required for the back, please provide separate files for each side.

File Formats and Submission:

The preferred file format for artwork submission is PDF.

We also accept AI, EPS, TIFF, or JPEG formats. If submitting JPEG files, ensure they are saved at maximum quality with minimal compression.

Important Notes:

Do not include trim marks, cut lines, badge outlines, hole/slot outlines, or any other printing guides in the artwork.

Please include a 5mm bleed on all sides.

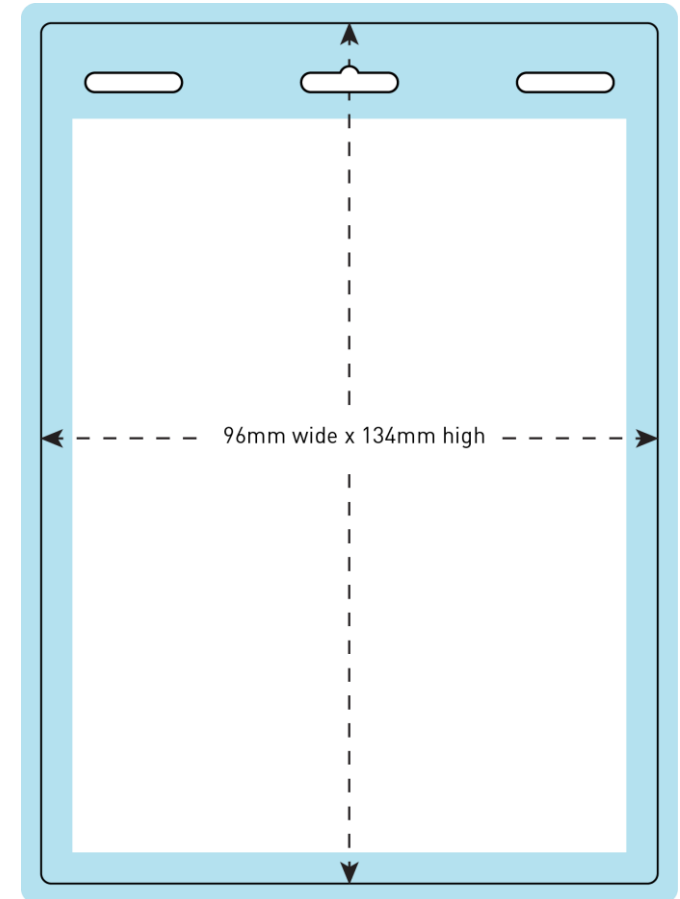

Image shown includes bleed

Printing and Design Specifications:

Fanfold badges are printed in one pass in full colour, on a carrier sheet. When printed the badge is peeled off, folded in half, and can then be attached to a lanyard or clip.

The Fanfold Standard dimensions are 96mm wide by 82mm high.

For images and text included in the artwork, please maintain a margin of at least 5mm from the edge of the badge.

Attachment and Layout Considerations:

The top of the badge includes three slots for lanyard attachment. Ensure your design accommodates these slots and avoids placing any logos, text, or important elements within the top 15mm of the badge.

Barcode Requirements:

If barcodes are to be included, they must be printed on a plain white area or on a very light colour tint that is at least 50mm wide by 20mm high. This area should be clear of the edges and slots.

Artwork Preparation:

Create artwork in CMYK colour mode at a resolution of 300 dpi.

Badges are printed with the same artwork for the front and the back (when folded). If different artwork is required for the back, please provide separate files for each side.

File Formats and Submission:

The preferred file format for artwork submission is PDF.

We also accept AI, EPS, TIFF, or JPEG formats. If submitting JPEG files, ensure they are saved at maximum quality with minimal compression.

Important Notes:

Do not include trim marks, cut lines, badge outlines, hole/slot outlines, or any other printing guides in the artwork.

Please include a 5mm bleed on all sides.

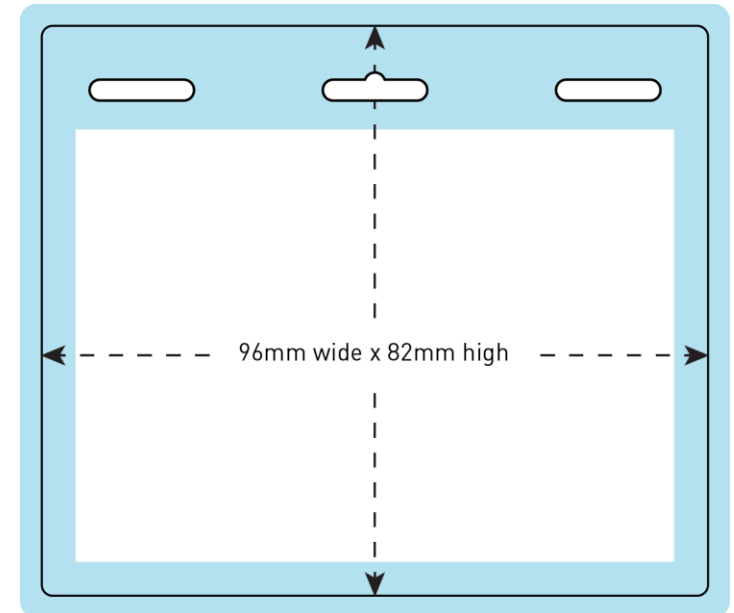

Image shown includes bleed

Printing and Design Specifications:

Peel and Stick (Butterfly) badges are printed in full colour on an A5 carrier sheet. The badge peels off the carrier, folds in half, and can be attached to a lanyard or clip.

The Large Peel and Stick (Butterfly) badge dimensions are 95mm wide by 120mm high.

Please ensure a minimum 5mm bleed is included in your design. For images and text that are not intended to bleed, maintain a margin of at least 4mm from the badge edge.

Attachment and Layout Considerations:

The top of the badge includes a slot for lanyard attachment. 6mm down from the top of the badge (not including bleed) are two 5mm diameter holes positioned 5mm from the left and right edges, and a centrally positioned euroslot that is 5mm high and 15mm wide

Ensure your design accommodates these slots and avoids placing any logos, text, or important elements within the top 15mm of the badge.

Barcode Requirements:

If barcodes are to be included, they must be printed on a plain white area or on a very light colour tint that is at least 50mm wide by 20mm high. This area should be clear of the edges and slots.

Artwork Preparation:

Create artwork in CMYK colour mode at a resolution of 300 dpi.

Badges are printed with the same artwork for the front and the back (when folded). If different artwork is required for the back, please provide separate files for each side.

File Formats and Submission:

The preferred file format for artwork submission is PDF.

We also accept AI, EPS, TIFF, or JPEG formats. If submitting JPEG files, ensure they are saved at maximum quality with minimal compression.

Important Notes:

Do not include trim marks, cut lines, badge outlines, hole/slot outlines, or any other printing guides in the artwork.

Please include a 5mm bleed on all sides.

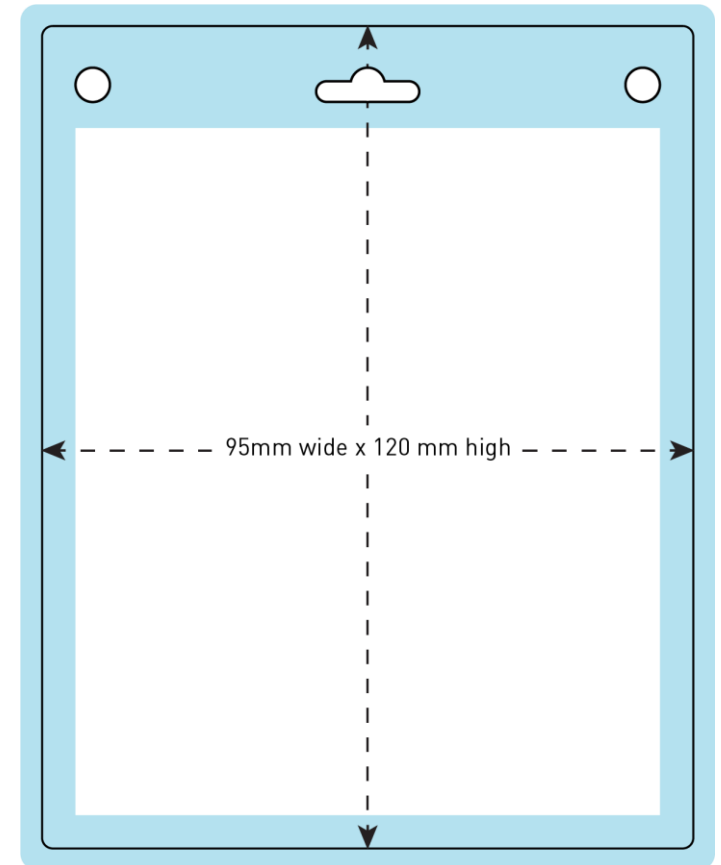

Image shown includes bleed

Butterfly Standard

Printing and Design Specifications:

Peel and Stick (Butterfly) badges are printed individually in full colour on an A5 carrier sheet. The badge peels off the carrier, folds in half, and can be easily attached to a lanyard or clip. The dimensions of the Peel and Stick (Butterfly) badge are 95mm wide by 80mm high. Please include a 5mm bleed in your design. For images and text that are not intended to bleed, maintain a margin of at least 4mm from the badge edge.

Attachment and Layout Considerations:

The top of the badge includes three slots for lanyard attachment. 6mm down from the top of the badge (not including bleed) are two 5mm diameter holes positioned 5mm from the left and right edges, and a centrally positioned euroslot that is 5mm high and 15mm wide.

Ensure your design accommodates these slots and avoids placing any logos, text, or important elements within the top 15mm of the badge.

Barcode Requirements:

If barcodes are to be included, they must be printed on a plain white area or on a very light colour tint that is at least 50mm wide by 20mm high. This area should be clear of the edges and slots.

Artwork Preparation:

Create artwork in CMYK colour mode at a resolution of 300 dpi.

Badges are printed with the same artwork for the front and the back (when folded). If different artwork is required for the back, please provide separate files for each side.

File Formats and Submission:

The preferred file format for artwork submission is PDF.

We also accept AI, EPS, TIFF, or JPEG formats. If submitting JPEG files, ensure they are saved at maximum quality with minimal compression.

Important Notes:

Do not include trim marks, cut lines, badge outlines, hole/slot outlines, or any other printing guides in the artwork.

Please include a 5mm bleed on all sides.

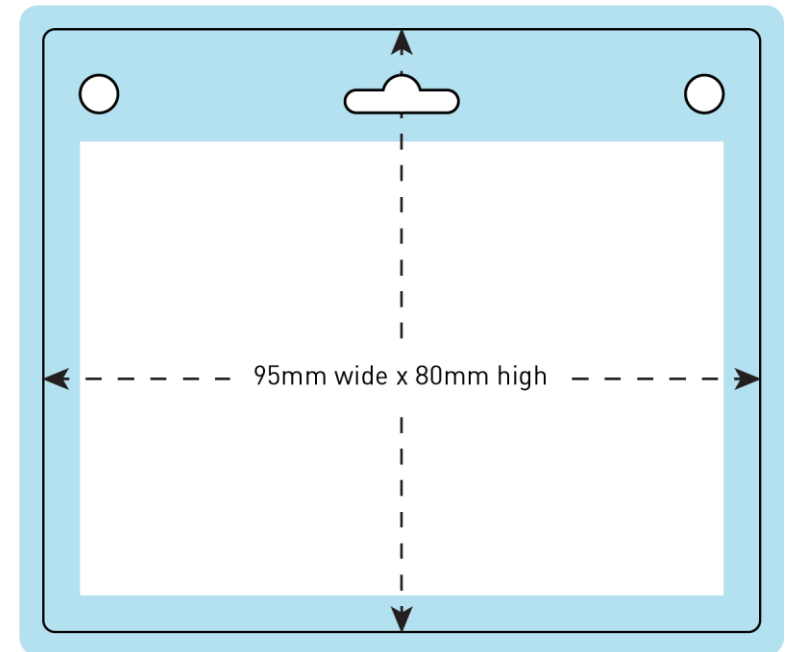

Image shown includes bleed

Printing and Design Specifications:

The standard plastic badge measures 85.5mm x 54mm. Please include a 3mm bleed in your design.

For images and text that are not intended to bleed, maintain a margin of at least 4mm from the card edge.

Keep in mind that the badge will have a 3mm radius corner, so be sure to account for this when positioning images and text.

Attachment and Layout Considerations:

If your badge or luggage tag requires a hole or slot, ensure that all images and text are at least 4mm clear of the edge of the hole or slot. A punched hole has a diameter of 5mm, with its top edge positioned 4mm from the card edge. A punched slot measures 14mm wide by 3mm high, with the top edge 4mm from the card edge.

Barcode Requirements:

If barcodes are to be included, they must be printed on a plain white area or on a very light colour tint that is at least 50mm wide by 20mm high. This area should be clear of the edges and slots.

Artwork Preparation:

Create artwork in CMYK colour mode at a resolution of 300 dpi.

Badges are printed single-sided (with the option of double-sided). If specific artwork is required for the back of the badge, please provide a separate file for each side.

File Formats and Submission:

The preferred file format for artwork submission is PDF.

We also accept AI, EPS, TIFF, or JPEG formats. If submitting JPEG files, ensure they are saved at maximum quality with minimal compression.

Important Notes:

Do not include trim marks, cut lines, badge outlines, hole/slot outlines, or any other printing guides in the artwork.

Please include a 3mm bleed on all sides.

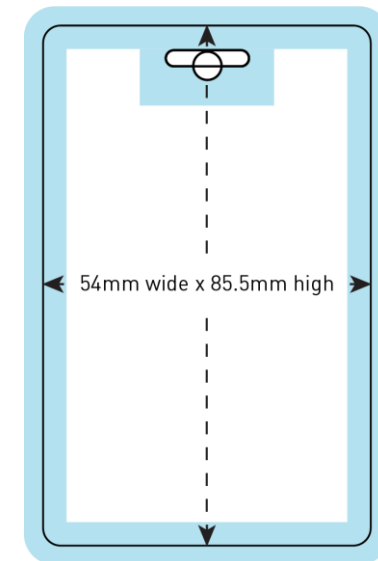
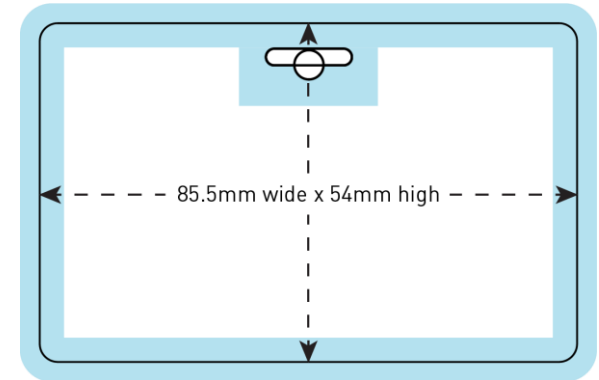

Image shown includes bleed

Printing and Design Specifications:

The artwork size for A6 paper badges is 95mm wide by 138mm high.

When printed, the complete artwork will be printed, there will then be a 5mm white border around the edges of the artwork. There is no need to include bleed in your design.

Attachment and Layout Considerations:

Since the badges will be placed in plastic wallets, there is no need to leave space for a hole.

Barcode Requirements:

If barcodes are to be included, they must be printed on a plain white area or on a very light colour tint that is at least 50mm wide by 20mm high. This area should be clear of the edges and slots.

Artwork Preparation:

Create artwork in CMYK colour mode at a resolution of 300 dpi.

Badges are printed with the same artwork for the front and the back (when folded). If different artwork is required for the back, please provide separate files for each side.

File Formats and Submission:

The preferred file format for artwork submission is PDF.

We also accept AI, EPS, TIFF, or JPEG formats. If submitting JPEG files, ensure they are saved at maximum quality with minimal compression.

Important Notes:

Do not include trim marks, cut lines, badge outlines, hole/slot outlines, or any other printing guides in the artwork.

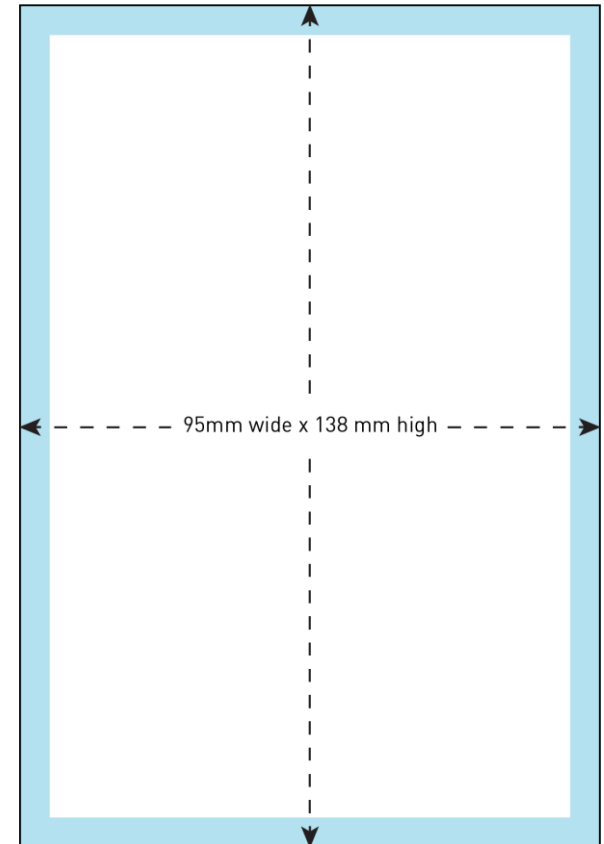

The PrintPod allows attendees to scan their barcode upon arrival at the event, automatically printing their event badge on-site. Both the front and side panels of the PrintPod can be customised with your graphics.

Panel Dimensions:

Panel Dimensions: 421mm wide x 802mm high

Artwork Specifications:

Please add a 15mm bleed on all sides.

Design Considerations:

Margins: Keep all important information at least 50mm from the edge of the artwork.

Top Area: Avoid placing any critical elements in the top 400mm of the front panel, as this area will include a cutout and tray for badge collection.

Material Specifications: If you are printing your own graphic panels, they should be mounted on 2mm Foamex board.

Panel Requirements: Please ensure you provide panels for both the front and sides of the PrintPod.

Artwork Preparation:

Create artwork in CMYK colour mode at a resolution of 300 dpi.

File Formats and Submission:

The preferred file format for artwork submission is PDF.

We also accept AI, EPS, TIFF, or JPEG formats. If submitting JPEG files, ensure they are saved at maximum quality with minimal compression.

Important Notes:

Do not include trim marks, cut lines, hole/slot outlines, or any other printing guides in the artwork.

Please include a 15mm bleed on all sides.

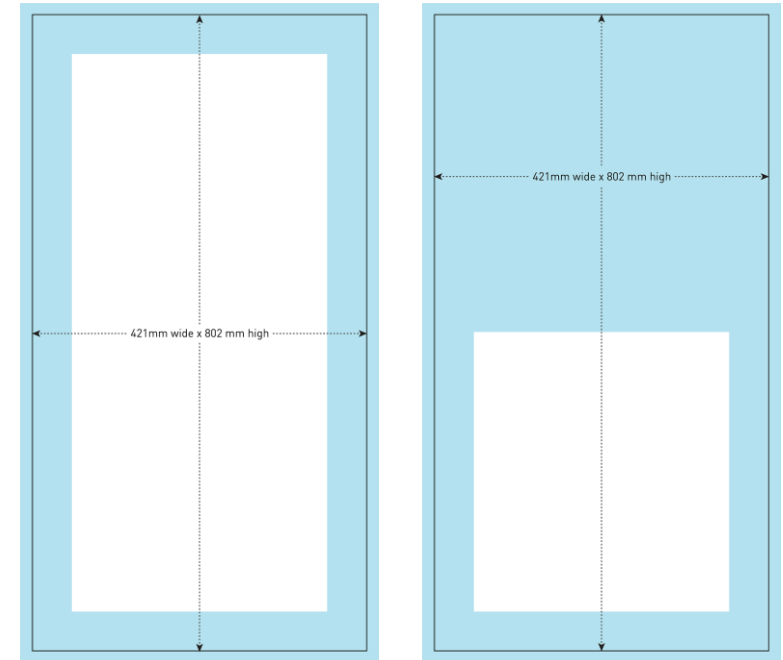

Image shown includes bleed

The ScanPod enables attendees to self-scan their badges at event entry points and key checkpoints, such as seminar entrances. The front panel can be customised with your graphics.

Panel Dimensions:

Panel Size: 244mm wide x 1385mm high

Artwork Specifications:

Please include a 10mm bleed on all sides

Design Considerations:

Margins: Keep all important information at least 30mm from the edge of the artwork.

Top Area: Avoid placing any critical elements in the top 200mm, as this area will be obscured by the scanning module and will not be visible.

Material Thickness: If you are printing your own graphic panels, they should be no more than 2mm to 3mm thick.

Artwork Preparation:

Create artwork in CMYK colour mode at a resolution of 300 dpi.

File Formats and Submission:

The preferred file format for artwork submission is PDF.

We also accept AI, EPS, TIFF, or JPEG formats. If submitting JPEG files, ensure they are saved at maximum quality with minimal compression.

Important Notes:

Do not include trim marks, cut lines, hole/slot outlines, or any other printing guides in the artwork.

Please include a 10mm bleed to all sides.

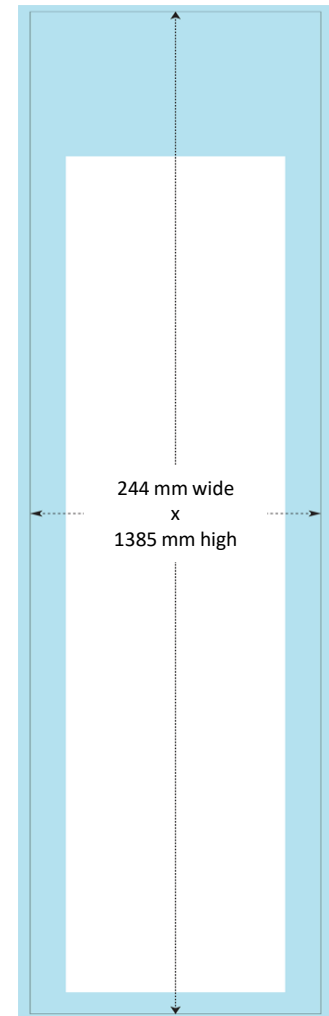

Image shown includes bleed